

RoboCylinder Series RCP6(S)

Slider / Rod / Radial / Table Type with Battery-less Absolute Encoder and External or Built-in Controller

Slider Type: SA

Standard Specification
Cleanroom Specification

(*) Model specifications of standard and cleanroom straight motor slider type are the same.

Series	Model (*)	Type	External View	Body Width (mm)	Lead (mm)	Positioning Repeatability (mm)	Stroke (mm)	Max. Speed (mm/s)		Max. Payload (kg)	
								Horizontal	Vertical	Horizontal	Vertical
RCP6	Straight Motor Spec.	SA4C		40mm	16	±0.01 [±0.005]	50~500 (50mm increments)	1260	7	1.5	
					10			785	12	3	
					5			390	14	5.5	
RCP6S	Straight Motor Spec.	SA6C		58mm	2.5	±0.01 [±0.005]	50~800 (50mm increments)	195	18	12	
					20			1440 <1280>	15	1	
					12			900	28	2.5	
RCP6CR	Cleanroom Spec.	SA7C		70mm	6	±0.01 [±0.005]	50~800 (50mm increments)	450	32	6	
					3			225	40	16	
					24			1200	37	3	
RCP6SCR	Cleanroom Spec.	SA8C		85mm	16	±0.01 [±0.005]	50~1100 (50mm increments)	980 <840>	46	8	
					8			245 <210>	55	25	
					4			1200 <850>	28	3	
RCP6	Side-mounted Motor Spec.	SA4R		40mm	20	±0.01	50~500 (50mm increments)	1260 <1120>	7	1.5	
					10			785	12	3	
					5			390	14	5.5	
RCP6S	Side-mounted Motor Spec.	SA6R		58mm	2.5	±0.01	50~800 (50mm increments)	195	18	12	
					20			1280 <1120>	15	1	
					12			900 <800>	28	2.5	
RCP6CR	Cleanroom Spec.	SA7R		70mm	6	±0.01	50~800 (50mm increments)	450	32	6	
					3			225	40	14	
					24			1080	37	3	
RCP6SCR	Cleanroom Spec.	SA8R		85mm	16	±0.01	50~1100 (50mm increments)	840 <700>	46	8	
					8			420	51	16	
					4			210	55	25	
RCP6	Side-mounted Motor Spec.	SA4R		40mm	30	±0.01	50~1100 (50mm increments)	1200 <850>	26	3	
					20			1000 <800>	55	4	
					10			500 <450>	70	25	
RCP6S	Side-mounted Motor Spec.	SA6R		58mm	5	±0.01	50~1100 (50mm increments)	250	80	55	
					20			250	80	55	
					10			250	80	55	

Values in brackets < > are for vertical use. Values in brackets [] are for high-precision specification.

Wide Slider Type: WSA

Standard Specification
Cleanroom Specification

(*) Model specifications of standard and cleanroom straight motor wide slider type are the same.

Series	Model (*)	Type	External View	Body Width (mm)	Lead (mm)	Positioning Repeatability (mm)	Stroke (mm)	Max. Speed (mm/s)		Max. Payload (kg)	
								Horizontal	Vertical	Horizontal	Vertical
RCP6	Straight Motor Spec.	WSA10C		100mm	16	±0.01 [±0.005]	50~500 (50mm increments)	840	4	-	
					10			610	15	-	
					5			390 <350>	28	3	
RCP6S	Straight Motor Spec.	WSA12C		120mm	2.5	±0.01 [±0.005]	50~800 (50mm increments)	195 <175>	40	10	
					20			800	12	-	
					12			600	25	-	
RCP6CR	Cleanroom Spec.	WSA14C		140mm	6	±0.01 [±0.005]	50~800 (50mm increments)	450 <400>	40	9	
					3			225	60	18	
					24			700	25	-	
RCP6SCR	Cleanroom Spec.	WSA16C		160mm	16	±0.01 [±0.005]	50~1100 (50mm increments)	560	50	-	
					8			420 <350>	65	14	
					4			210 <175>	80	26	
RCP6	Side-mounted Motor Spec.	WSA10R		100mm	20	±0.01	50~500 (50mm increments)	720	50	-	
					10			450 <240>	70	15	
					5			195 <170>	100	50	
RCP6S	Side-mounted Motor Spec.	WSA12R		120mm	16	±0.01	50~800 (50mm increments)	840	4	-	
					10			610	15	-	
					5			390 <305>	28	3	
RCP6CR	Cleanroom Spec.	WSA14R		140mm	2.5	±0.01	50~800 (50mm increments)	195 <175>	40	10	
					20			800	12	-	
					12			600	25	-	
RCP6SCR	Cleanroom Spec.	WSA16R		160mm	6	±0.01	50~800 (50mm increments)	450 <400>	40	9	
					3			225	60	16	
					24			700	25	-	
RCP6	Side-mounted Motor Spec.	WSA10R		100mm	16	±0.01	50~800 (50mm increments)	560	50	-	
					8			420 <350>	65	14	
					4			175	80	26	
RCP6S	Side-mounted Motor Spec.	WSA12R		120mm	20	±0.01	50~1100 (50mm increments)	600	30	-	
					10			365 <210>	70	15	
					5			170 <145>	100	45	

Values in brackets < > are for vertical use. Values in brackets [] are for high-precision specification.

Product Lineup



Rod Type: RA

Standard Specification
Dust/Splash-proof Specification

(*) Model specifications of standard straight and side-mounted motor rod type.
For dust/splash-proof rod type please refer to the RCP6(S)CR/W catalogue extract.

Series	Model (*)	Type	External View	Body Width (mm)	Lead (mm)	Positioning Repeatability (mm)	Stroke (mm)	Max. Speed (mm/s)	Max. Push Force (N)	Max. Payload (kg)		
										Horizontal	Vertical	
RCP6	Straight Motor Spec.	RA4C		40mm	16	±0.01	50~200 (50mm increments)	840	48	6	1.5	
					10			700	77	15	2.5	
					5			350	155	28	5	
		RA6C	58mm	2.5	±0.01	50~300 (50mm increments)	175	310	40	10	6	1.5
				20			800	56	6	1.5		
				12			700	93	25	4		
	RA7C	70mm	70mm	6	±0.01	50~300 (50mm increments)	450	185	40	10	20	
				3			225	370	60	20		
				24			860 <640>	182	20	3		
	RCP6S	RA8C	85mm	85mm	16	±0.01	50~300 (50mm increments)	700 <560>	273	50	8	
					8			420 <350>	547	60	18	
					4			210 <175>	1094	80	28	
RCP6W	Side-mounted Motor Spec.	RA4R	40mm	20	±0.01	50~200 (50mm increments)	600 <450>	500	30	5		
				10			300 <250>	1000	60	40		
				5			150	2000	100	70		
		RA6R	58mm	58mm	16	±0.01	50~300 (50mm increments)	840	48	5	1	
					10			610	77	12	2.5	
					5			350	155	25	5	
	RA7R	70mm	70mm	2.5	±0.01	50~300 (50mm increments)	175	310	40	10		
				20			800	56	6	1.5		
				12			700	93	25	4		
	RCP6SW	RA8R	85mm	85mm	6	±0.01	50~300 (50mm increments)	450	185	40	10	
					3			225	370	60	20	
					24			800 <640>	182	20	3	
RCP6SW	RA7R	70mm	70mm	16	±0.01	50~300 (50mm increments)	560	273	50	8		
				8			420 <350>	547	60	18		
				4			175	1094	80	28		
RCP6SW	RA8R	85mm	85mm	20	±0.01	50~300 (50mm increments)	400	500	30	5		
				10			200	1000	60	40		
				5			100	2000	100	70		

Values in brackets < > are for vertical use.

Radial Cylinder: RRA

Standard Specification
Dust/Splash-proof Specification

(*) Model specifications of standard straight and side-mounted motor radial cylinder.
For dust/splash-proof radial cylinder please refer to the RCP6(S)CR/W catalogue extract.

Series	Model (*)	Type	External View	Body Width (mm)	Lead (mm)	Positioning Repeatability (mm)	Stroke (mm)	Max. Speed (mm/s)	Max. Push Force (N)	Max. Payload (kg)		
										Horizontal	Vertical	
RCP6	Straight Motor Spec.	RRA4C		40mm	16	±0.01	60~410 (50mm increments)	1120	48	7	1.5	
					10			700	77	18	3	
					5			350	155	28	6	
		RRA6C	58mm	58mm	2.5	±0.01	65~415 (50mm increments)	175	310	40	10	
					20			800	56	6	1.5	
					12			700	93	25	4	
	RCP6S	Dust/Splash-proof Spec.	RRA7C	70mm	70mm	6	±0.01	70~520 (50mm increments)	450	185	40	10
						3			225	370	60	20
						24			860 <640>	182	20	3
	RCP6S	RRA8C	85mm	85mm	16	±0.01	50~700 (50mm increments)	700 <560>	273	50	8	
					8			420	547	60	18	
					4			210	1094	80	28	
RCP6W	Side-mounted Motor Spec.	RRA4R	40mm	40mm	20	±0.01	60~410 (50mm increments)	600 <450>	500	30	5	
					10			300 <250>	1000	60	40	
					5			150	2000	100	70	
		RRA6R	58mm	58mm	16	±0.01	65~415 (50mm increments)	840	48	5	1	
					10			610	77	13	2.5	
					5			350	155	28	5	
	RCP6SW	Dust/Splash-proof Spec.	RRA7R	70mm	70mm	2.5	±0.01	70~520 (50mm increments)	175	310	40	10
						20			800	56	6	1.5
						12			700	93	25	4
	RCP6SW	RRA8R	85mm	85mm	6	±0.01	50~700 (50mm increments)	450	185	40	10	
					3			225	370	60	20	
					24			860 <640>	182	20	3	
RCP6SW	RRA7R	70mm	70mm	16	±0.01	70~520 (50mm increments)	560	273	50	8		
				8			420 <350>	547	60	18		
				4			175	1094	80	28		
RCP6SW	RRA8R	85mm	85mm	20	±0.01	50~700 (50mm increments)	400	500	30	5		
				10			200	1000	60	40		
				5			100	2000	100	70		

Values in brackets < > are for vertical use.

Product Lineup

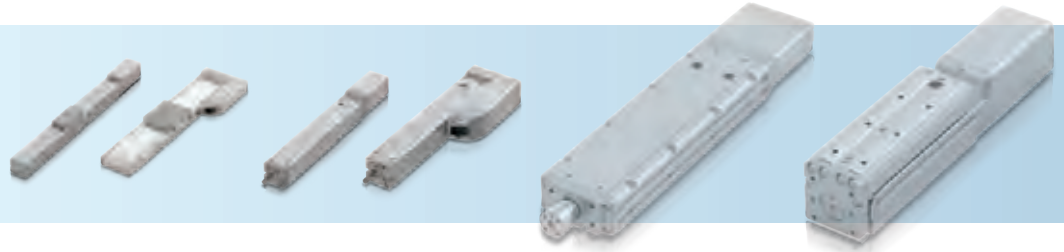

Wide Radial Cylinder: WRA

Standard Specification
Dust/Splash-proof Specification

(*) Model specifications of standard straight and side-mounted motor wide radial cylinder. For dust/splash-proof wide radial cylinder please refer to the RCP6(S)CR/W catalogue extract.

Series	Model (*)	Type	External View	Body Width (mm)	Lead (mm)	Positioning Repeatability (mm)	Stroke (mm)	Max. Speed (mm/s)	Max. Push Force (N)	Max. Payload (kg)	
										Horizontal	Vertical
RCP6	Straight Motor Spec.	WRA10C		100mm	16	±0.01	50~500 (50mm increments)	700	48	4	-
					10			525	77	14.5	-
					5			350 <260>	155	28	5
		WRA12C		120mm	20	±0.01	50~500 (50mm increments)	800	56	7.5	-
					12			560	93	30	-
					6			400 <340>	185	55	7.5
	Dust/Splash-proof Spec.	WRA14C		140mm	24	±0.01	50~600 (50mm increments)	630	182	25	-
					16			560	273	50	-
					8			420 <210>	547	65	15
	RCP6S	WRA16C		160mm	20	±0.01	50~800 (50mm increments)	450	500	30	-
	RCP6W	Side-mounted Motor Spec.	WRA10R		100mm	±0.01	50~500 (50mm increments)	700	48	4	-
	10							525	77	11.5	-
5	350 <260>							155	28	5	
Dust/Splash-proof Spec.	WRA12R			120mm	±0.01	50~500 (50mm increments)	800	56	7.5	-	
							12	560	93	30	-
							6	400 <280>	185	55	7.5
WRA14R		140mm	±0.01	50~600 (50mm increments)	630	182	25	-			
					16	560	273	50	-		
					8	350 <210>	547	65	15		
RCP6SW	WRA16R		160mm	20	±0.01	50~800 (50mm increments)	420	500	30	-	
				10		240 <180>	1000	60	34.5		
				5		120 <100>	2000	100	63		

Values in brackets < > are for vertical use.

Table Type: TA

Standard Specification

Series	Model	Type	External View	Body Width (mm)	Lead (mm)	Positioning Repeatability (mm)	Stroke (mm)	Max. Speed (mm/s)	Max. Payload (kg)	
									Horizontal	Vertical
RCP6	Straight Motor Spec.	TA4C		40mm	16 (*)	±0.01	SB Spec: 25~150 (25mm increments) DB Spec: 40, 65, 90, 140, 190, 240	980 <700>	3[-]	1[-]
					10			785 <700>	4[8]	2.5[2.5]
					5			390	5[10]	5[5]
		TA6C		58mm	20 (*)	±0.01	SB Spec: 25~200 (25mm increments) DB Spec: 45, 70, 95, 120~320 (50mm increments)	1120 <800>	5[-]	1[-]
					12			800[800<680>]	8[15]	3[3]
					6			400	10[20]	6[6]
	TA7C		70mm	24 (*)	±0.01	SB Spec: 25~300 (25mm increments) DB Spec: 40, 65, 90~390 (50mm increments)	1080 <860>	10[-]	3[-]	
				16			700 <560>	12[25]	7[7]	
				8			420 <350>	15[30]	16[16]	
RCP6S	TA4R		40mm	20 (*)	±0.01	SB Spec: 25~150 (25mm increments) DB Spec: 40, 65, 90, 140, 190, 240	980 <700>	3[-]	1[-]	
				10		785 <700>[700<525>]	4[8]	2.5[2.5]		
				5		390	5[10]	5[5]		
Side-mounted Motor Spec.	TA6R		58mm	20 (*)	±0.01	SB Spec: 25~200 (25mm increments) DB Spec: 45, 70, 95, 120~320 (50mm increments)	1120 <800>	5[-]	1[-]	
				12			800 <680>	8[15]	3[3]	
				6			400	10[20]	6[6]	
	TA7R		70mm	24 (*)	±0.01	SB Spec: 25~300 (25mm increments) DB Spec: 40, 65, 90~390 (50mm increments)	1080 <860>	10[-]	3[-]	
				16			700 <560>	12[25]	7[7]	
				8			420 <350>	15[30]	16[16]	
				4		210	15[30]	20[24]		

(*) Only single-block (SB) specification. Values in brackets < > are for vertical use. Values in brackets [] are for the double-block (DB) specification.

Shape Types and Features

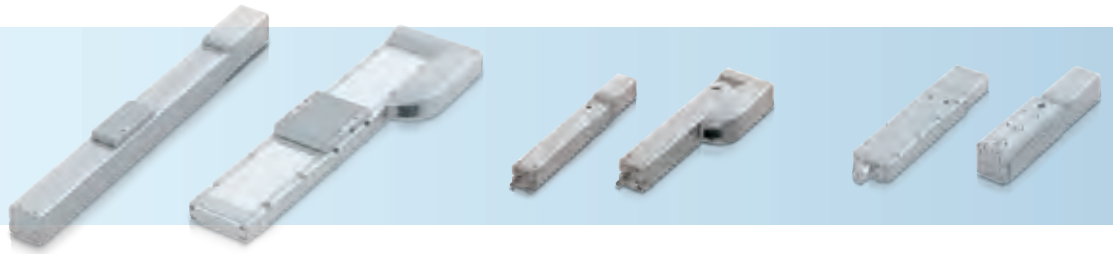

Slider Type: SA

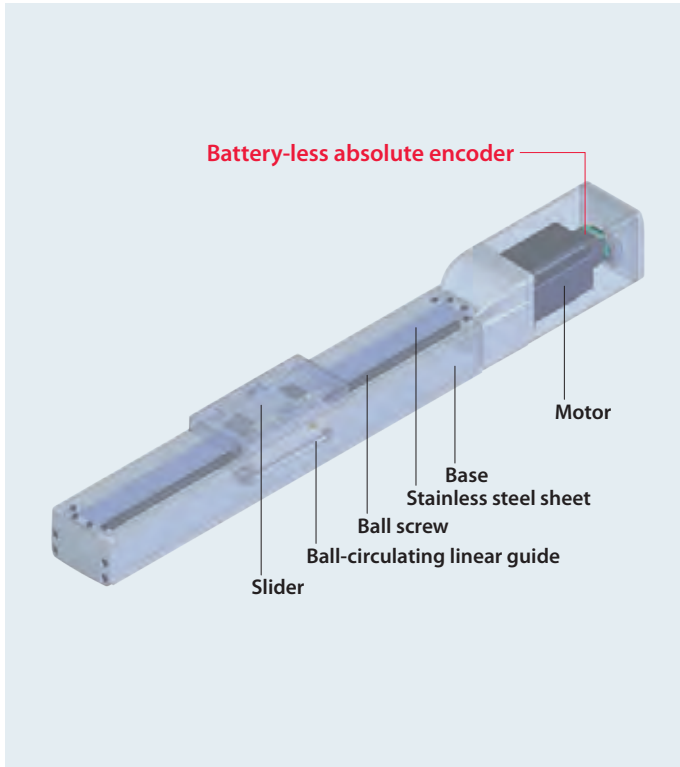

Features

- ▶ With a base integrated ball circulating linear guide, it will be able to deal with moments in the pitching (Ma), yawing (Mb), and rolling (Mc) directions.
- ▶ By combining multiple axes, two-dimensional and three-dimensional operations are possible.

Usage examples

- Switching from rod-less air cylinder
- Switching from self-made equipment with ballscrew, guide, and motor.
- Using as base and movable axes of the cartesian system.
- Work such as assembly, inspection, and measuring length that require high accuracy.

Wide Slider Type: WSA

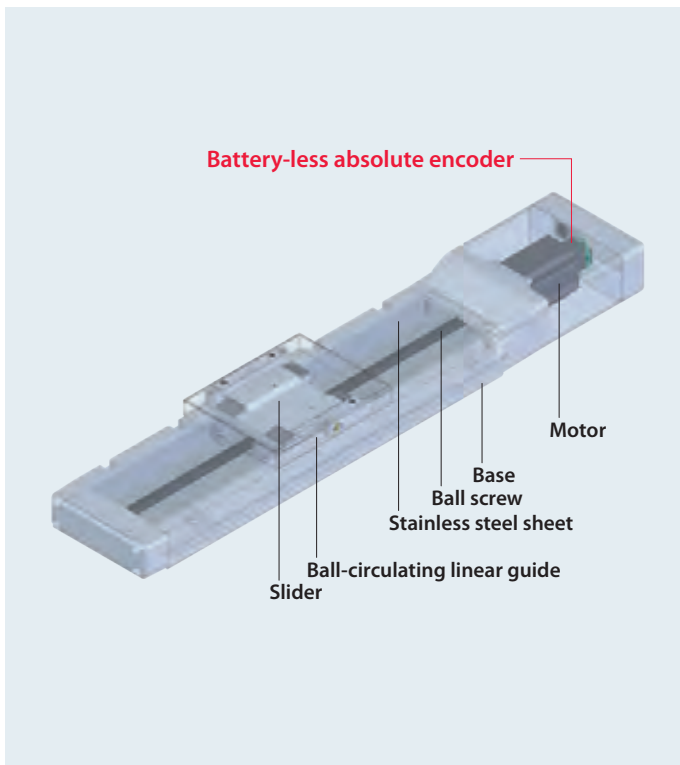

Features

- ▶ Perfect for the base axis of the cartesian system. With a built-in ball circulating linear guide inside its wide body, it will be able to deal with moments in the pitching (Ma), yawing (Mb), and rolling (Mc) directions.
- ▶ 2nd axis can be installed onto the wide slider type without removing its stainless steel sheet.
- ▶ By combining multiple axes, two-dimensional and three-dimensional operations are possible.

Usage examples

- Switching from rod-less air cylinder
- Switching from self-made equipment with ballscrew, guide, and motor.
- Work such as assembly, inspection, and measuring length that require high accuracy.

Shape Types and Features



Rod Type: **RA**

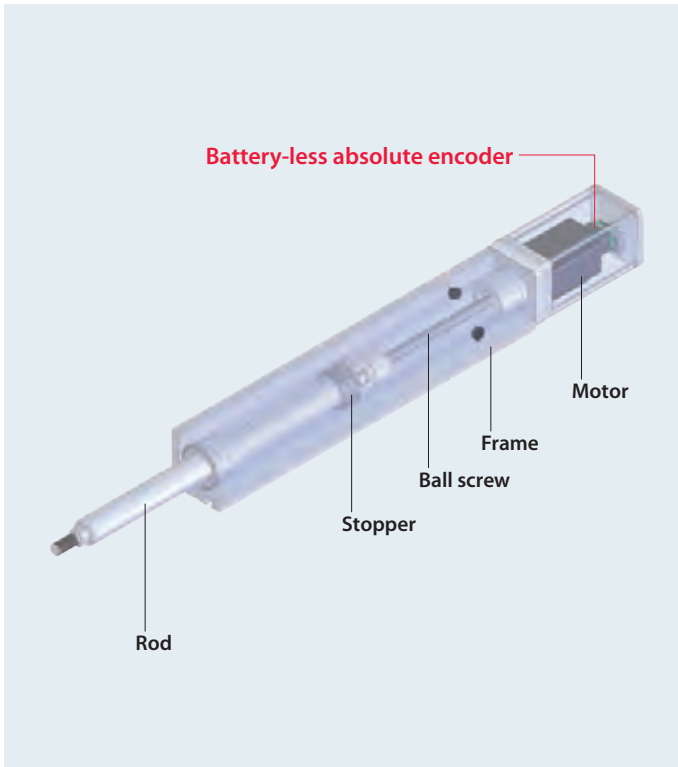

Features

- ▶ This is a type that does not build in a linear guide inside of the actuator. Of the RCP6 rod-types that resemble air cylinders, this is the least expensive model.

Usage examples

- Switching from rod type air cylinder
- Push force combined with a guide
- Inserting, press-fitting, or riveting a work
- Using as a lifter or a work piece unloader

Radial Cylinder: **RRA**

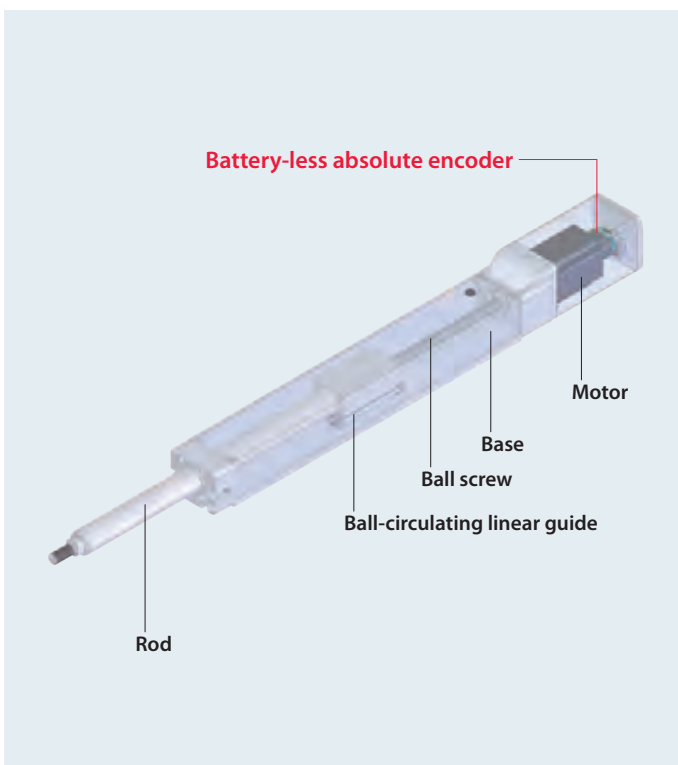

Features

- ▶ Since ball circulating linear guides are built in, it can take radial loads and moment loads. The vibration upon stopping can be suppressed and a long stroke of up to 700mm has become possible. In addition, product quality has significantly increased with a non-rotating rod precision of "0 degree" with a no load condition.
- ▶ The equipment will be compact since an external guide is unnecessary.

Usage examples

- Inserting, press-fitting, or riveting a work
- Using as a lifter or a work piece unloader
- Using as a movable vertical axis of the cartesian system
- Transferring or positioning a lightweight object

Shape Types and Features

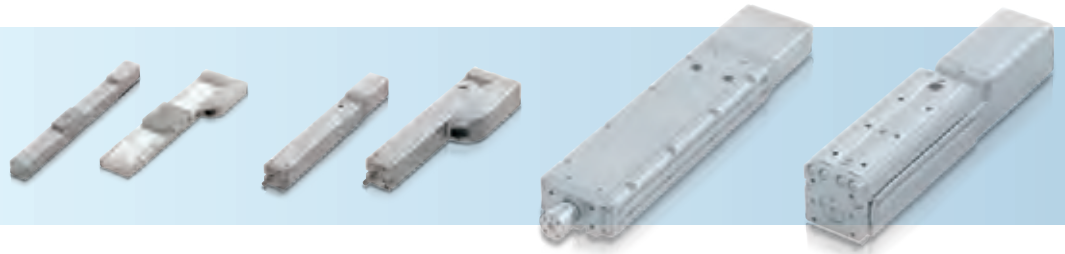

Wide Radial Cylinder: **WRA**

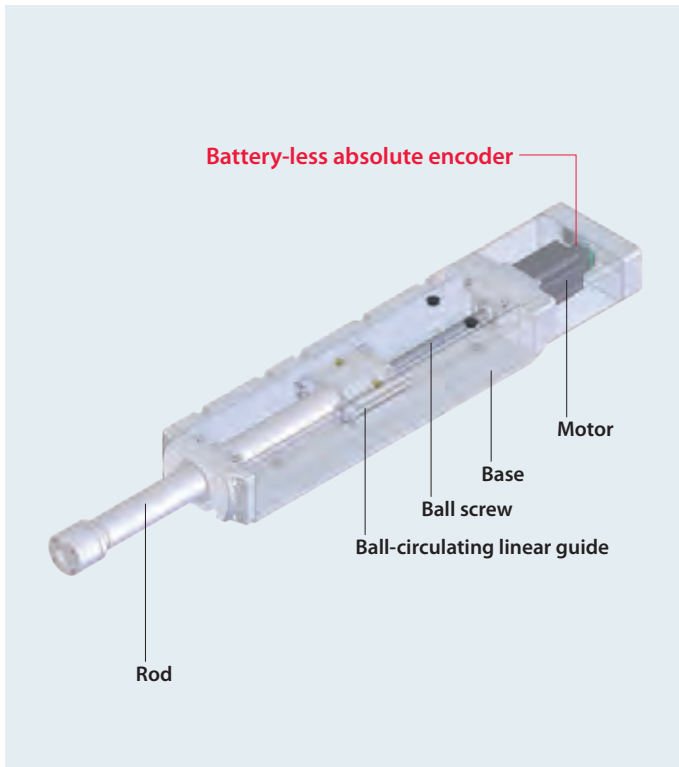

Features

- ▶ Due to a wide body and high-rigidity rod, it can deal with up to four times the allowable torque on rod tip compared to a standard radial cylinder. Due to a high dynamic allowable moment, it can be utilized for uses such as tightening screws and stirring that have large load torque.
- ▶ The equipment will be compact since an external guide is unnecessary.

Usage examples

- Inserting, press-fitting, or riveting a work
- Tightening a screw or stirring
- Using as a lifter or a work piece unloader
- Using as a movable vertical axis of the cartesian system
- Transferring or positioning a lightweight object
- Using as a base axis of the pick-and-place unit

Table Type: **TA**

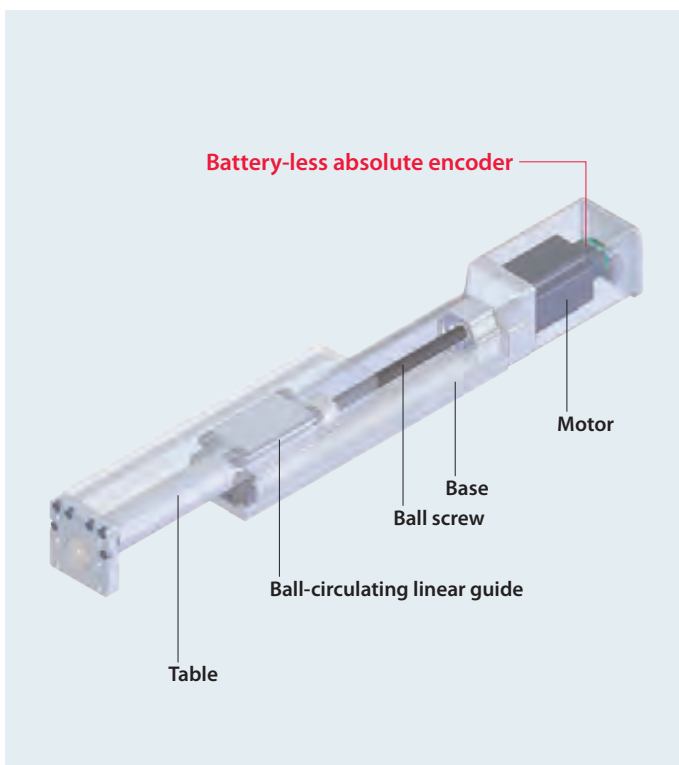

Features

- ▶ Work piece can be installed using the tapped mounting holes on the top surface of the table and the tip plate.
- ▶ With a built-in ball circulating linear guide in the table section, it will be able to deal with moments in the pitching (M_a), yawing (M_b), and rolling (M_c) directions.
- ▶ High-rigidity specification (double-block) can be selected as an option. With two guide blocks, the dynamic allowable moment increases by up to 4.3 times in the pitching (M_a) and yawing (M_b) directions.

Usage examples

- Switching from table type air cylinder
- Clamping tasks that pinch work from both sides
- Positioning tasks that hold work with the front side of the table
- A function for pushing works on a conveyor to the side
- Using as a movable vertical axis of the cartesian system

Built-in Controller Type

RCP6S

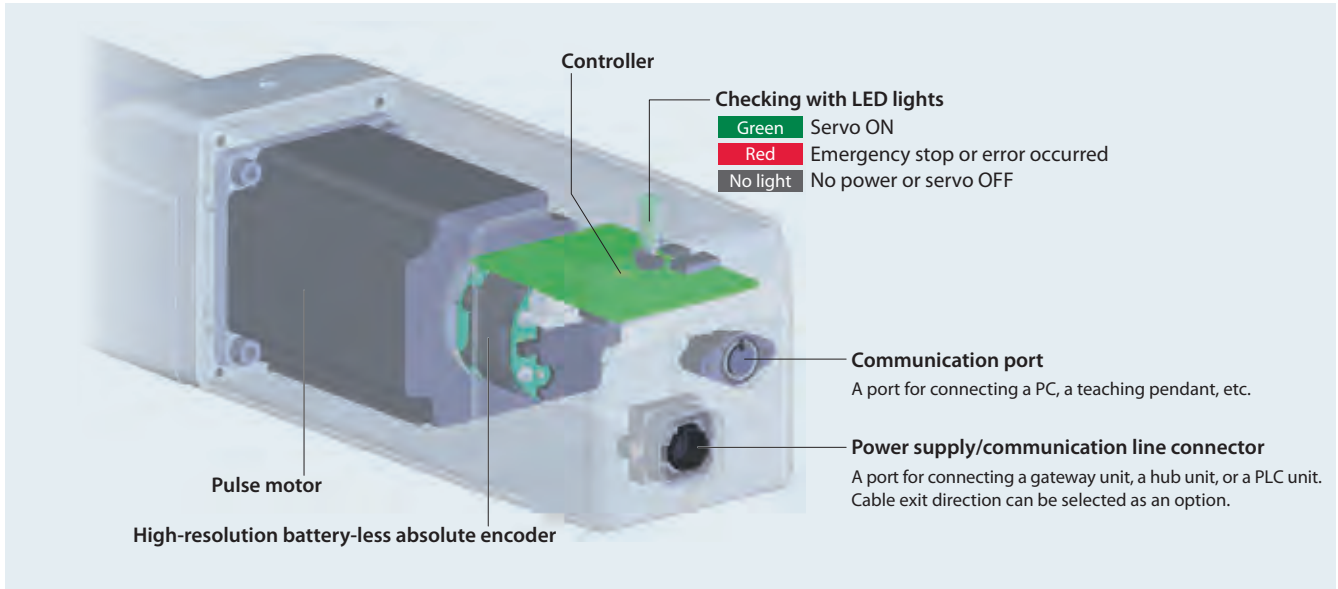

RCP6S Peripheral Equipment

*Gateway unit or PLC connection unit is required to operate the RCP6S.

1 Gateway Unit



- ▶ Compatible field networks
The gate unit can be used with the following 6 types of field networks.

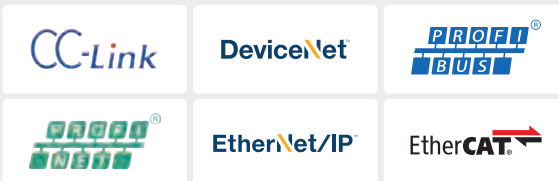

- ▶ 4 RCP6S' or 4 hub units can be connected to a gateway unit.
- ▶ Brake can be forcibly released by supplying power to the brake release input terminal of external power input for each channel. (In the case that the actuator is directly connected)

- ▶ The communication time when RCP6S is connected directly is 10ms, while it is 40ms when using the RCP6S with a hub unit. There will be no change in communication time when the number of connected actuators is increased.

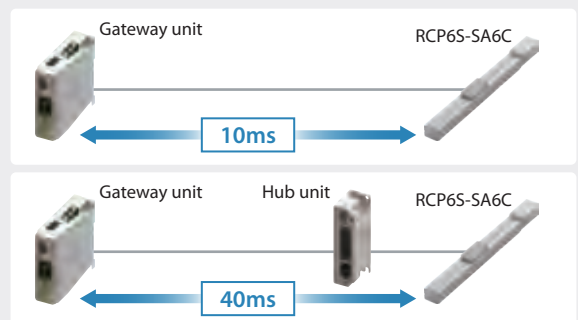

2 Hub Unit



- ▶ A hub unit is a signal distribution unit used by combining with a gateway unit.
- ▶ A gateway unit and a hub unit, or a hub unit and a RCP6 are each connected with a serial communication.
- ▶ A maximum of 4 RCP6S' can be connected.
- ▶ By operating the brake release switch, ON/OFF actions of the brake can be performed.

3 PLC Connection Unit



- ▶ A PLC connection unit is a unit to be moved with serial communication from a master controller or a PLC by combining it with RCP6S.
- ▶ A RCP6S and a PLC connection unit can be connected with a cable with connectors.

Selectable Built-in or Separate Controller Type for all Models

The advantages of a built-in controller type.

- ▶ Smaller control panel.
- ▶ Simple wiring.
- ▶ Less maintenance parts necessary because wires are being shared.

By using the gateway unit and the hub unit(s), it is possible to reduce the size of the control panel and a number of cables.

Control Panel for Standard Controller

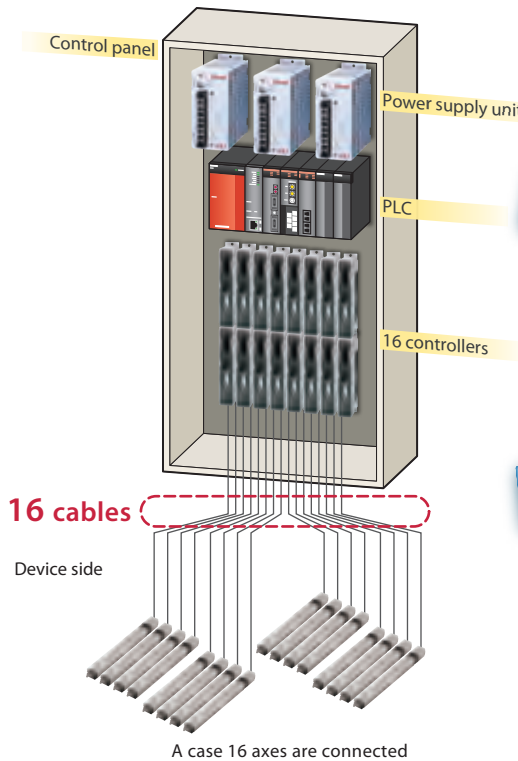

Control Panel for the RCP6S Built-in Controller Actuator

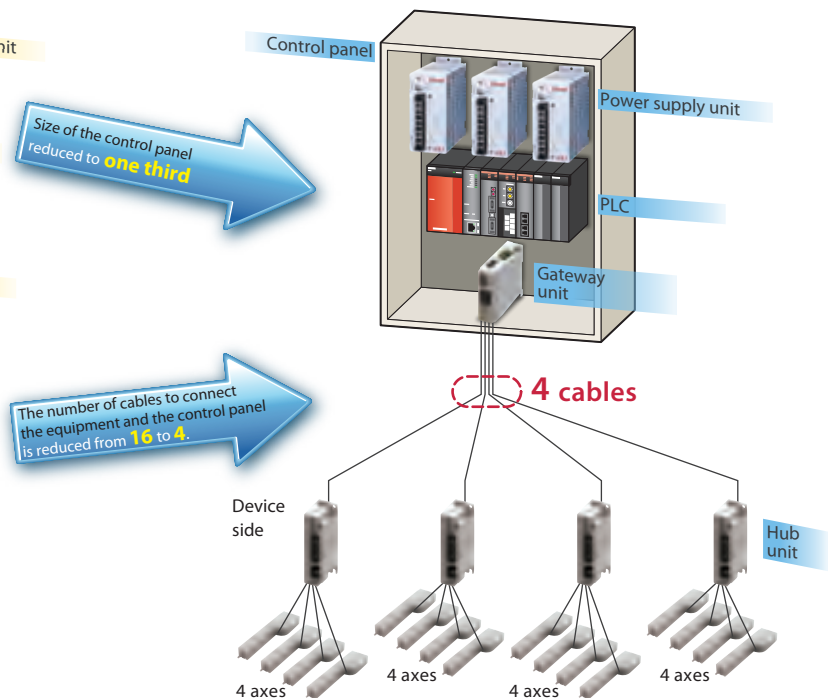

Size of the control panel reduced to **one third**

The number of cables to connect the equipment and the control panel is reduced from **16 to 4**.

* Maximum cable length between the gateway unit and RCP6S is 20m. If there is a hub unit in between, the maximum length is still 20m. The cable length from the gateway unit to the hub unit needs to be 10m or less.

Applicable External Controllers for RCP6 (Standard/Separate Controller Type)

PCON-CB/CFB

Single-axis Position Controller



Max. number of controlled axes: 1 axis (RCP6)

Max. positioning points: 512 points (for network spec, 768 points)

MCON-C | RCON

Multi-axis Position Controller



MCON-C

Max. number of controlled axes: 4 axes (RCP6)

Max. positioning points: 256 points

RCON

Max. number of controlled axes: 16 axes (RCP6)

Max. positioning points: 128 points

MSEL

Multi-axis Program Controller



Max. number of controlled axes: 4 axes (RCP6)

Max. positioning points: 30000 points